

NEROXDOMO[®]

PRIME 3H & PRIME 5H

manual de instalación **2** **ESP**

installation manual **5** **ENG**

manuel d'installation **8** **FRA**



PRIME 3H I5657000
PRIME 5H I5657002

Instalación del motor

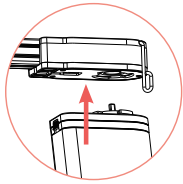

Insertar el eje del Motor en la Polea motor

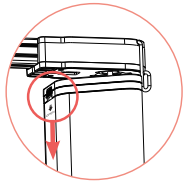

Deslizar hacia abajo la pestaña de bloqueo del Motor

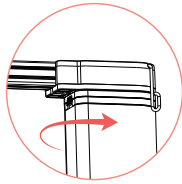

Girar el Motor y soltar la pestaña de bloqueo del Motor

Montaje

Desmontaje

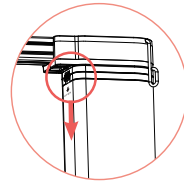

Deslizar hacia abajo la pestaña de bloqueo del Motor

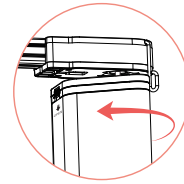

Girar el Motor sin soltar la pestaña de bloqueo del Motor

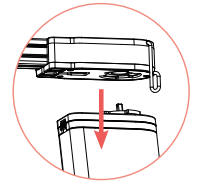

Quitar el Motor

Esquemas de conexiones cable de alimentación

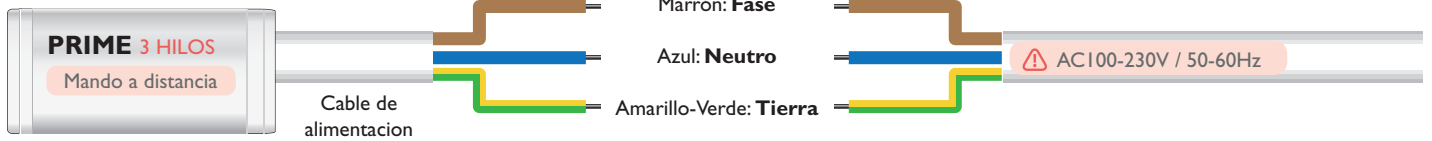

Mandos a distancia

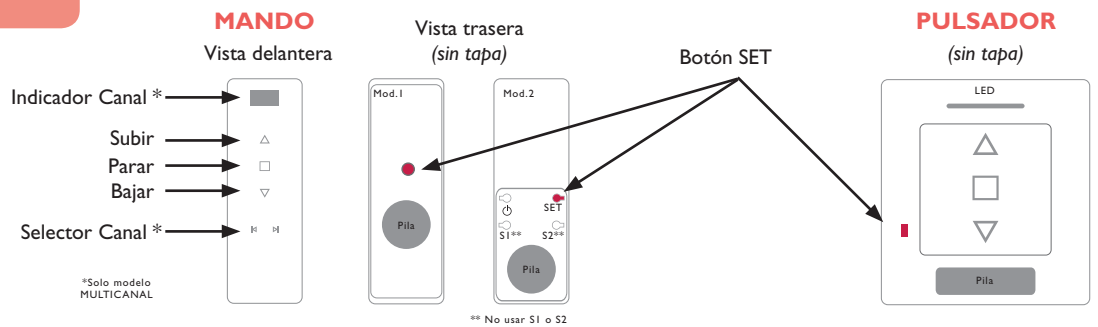

Motor

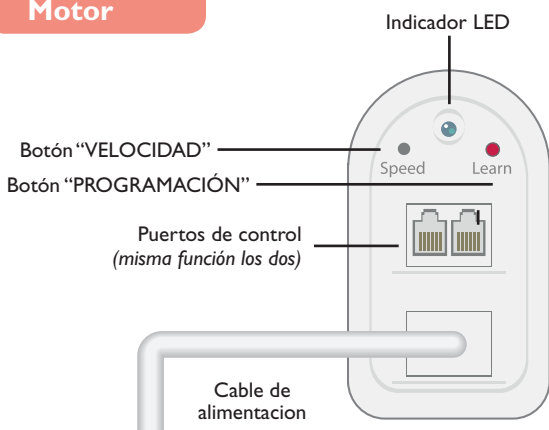

Conexión cable de control (opcional)

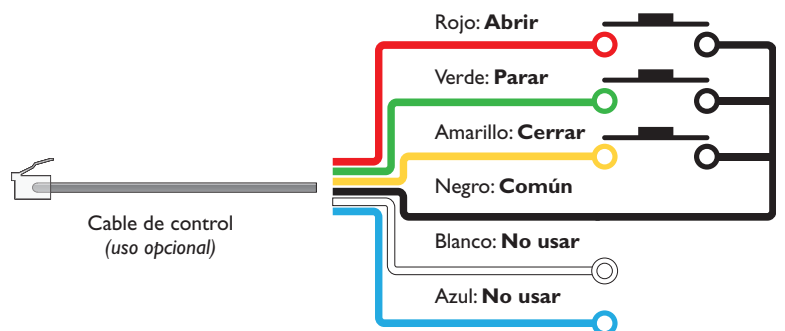

Programación básica

⚠ El tiempo entre instrucciones debe ser inferior a 10 segundos o el Motor saldrá del Modo Programación

1. Programación del Mando a distancia / Canal

⚠ Si se usa el Mando Multicanal, elegir previamente el canal

 <p>1.1 Pulsar SET durante 1 seg.</p>	 <p>1.2 El indicador ROJO parpadeará lentamente</p>	 <p>1.3 Pulsar SUBIR una vez</p>	 <p>1.4 El indicador AZUL parpadeará 3 veces</p>	 <p>1.5 MANDO / CANAL programado</p>
--	--	---	---	---

2. Cambio del sentido de apertura (solo si es necesario)



 <p>2.1 Pulsar PARAR durante 5 seg.</p>	 <p>2.2 El indicador ROJO parpadeará lentamente</p>	 <p>2.3 Pulsar PARAR una vez</p>	 <p>2.4 El indicador AZUL parpadeará 3 veces</p>	 <p>2.5 SENTIDO cambiado</p>
--	--	---	---	---

Funciones adicionales

⚠ El tiempo entre instrucciones debe ser inferior a 10 segundos o el Motor saldrá del Modo Programación



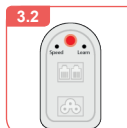
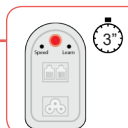
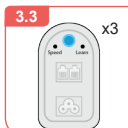

3. Activación / Desactivación de la función Light Touch (Función Light Touch: El Motor arranca automáticamente al desplazar la cortina 5 cm)

⚠ Esta función está activada por defecto



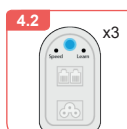
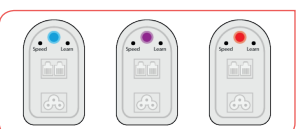

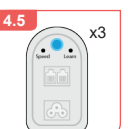
 <p>3.1 Pulsar SET durante 7 seg.</p>	 <p>3.2 El indicador ROJO comenzará a parpadear lentamente</p>	 <p>3.3 El indicador ROJO parpadeará rápidamente pasados 3 seg.</p>	 <p>3.4 El indicador AZUL parpadeará 3 veces pasados 7 seg.</p>	 <p>3.5 FUNCIÓN LIGHT TOUCH activada / desactivada</p>
--	---	--	--	---

4. Cambio del nivel de velocidad del motor

⚠ El Motor dispone de 3 niveles de velocidad. El nivel de velocidad máximo está seleccionado por defecto.

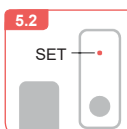
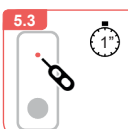
 <p>4.1 Pulsar el botón VELOCIDAD durante 3 seg.</p>	 <p>4.2 El indicador AZUL parpadeará 3 veces</p>	 <p>4.3 Indicador AZUL: 101-130RPM Indicador MORADO: 81-100RPM Indicador ROJO: 50-80RPM</p>	 <p>4.4 Pulsar SET para cambiar el nivel de velocidad</p>	 <p>4.5 Pulsar el botón VELOCIDAD durante 3 seg.</p>	 <p>4.6 El indicador AZUL parpadeará 3 veces</p>	 <p>4.7 NIVEL DE VELOCIDAD cambiado</p>
---	---	--	--	--	---	--

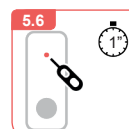
5. Ajuste fino del Final de Carrera

 <p>5.1 Mover hasta el FINAL DE CARRERA a ajustar</p>	 <p>5.2 Quitar tapa para acceder al botón SET</p>	 <p>5.3 Pulsar SET durante 1 seg.</p>	 <p>5.4 El indicador AZUL parpadeará 3 veces</p>	 <p>5.5 Ajustar a la posición deseada (también manualmente)</p>	 <p>5.6 Pulsar SET durante 1 seg.</p>	 <p>5.7 El indicador AZUL parpadeará 3 veces</p>	 <p>5.8 NUEVA POSICIÓN ajustada</p>
--	--	--	---	--	---	---	--

6. Añadir Mando a distancia / Canal usando otro programado

 <p>6.1 Pulsar PARAR durante 5 seg.</p>	 <p>6.2 El indicador ROJO parpadeará lentamente</p>	 <p>6.3 Pulsar SUBIR en el nuevo Mando / Canal</p>	 <p>6.4 El indicador AZUL parpadeará 3 veces</p>	 <p>6.5 Nuevo MANDO A DISTANCIA / CANAL añadido</p>
--	--	---	---	--

7. Borrado de Mando a distancia

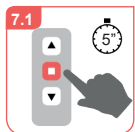

Pulsar PARAR durante 5 seg.



El indicador ROJO parpadeará lentamente



Pulsar BAJAR

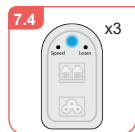

El indicador AZUL parpadeará 3 veces



MANDO A DISTANCIA / CANAL borrado

8. Bloqueo/Desbloqueo del número de canales disponibles (Sólo en Mando Multicanal)

8A. Bloqueo de canales



Para bloquear: Situarse en el canal deseado



Pulsar PARAR y flecha DERECHA durante 5 seg.



NUMERO DE CANALES bloqueado

8B. Desbloqueo de canales



Para desbloquear: Situarse en cualquier canal

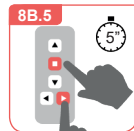

Pulsar PARAR y flecha DERECHA durante 5 seg.



NUMERO DE CANALES desbloqueado

Borrado completo (Reset de fábrica)

⚠ El tiempo entre instrucciones debe ser inferior a 10 segundos o el Motor saldrá del Modo Programación

⚠ El Borrado Completo eliminará: Finales de carrera y Mandos a distancia / Canales

9A. Borrado completo desde el Mando a distancia

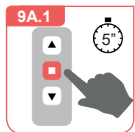

Pulsar PARAR durante 5 seg.

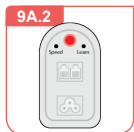

El indicador ROJO parpadeará lentamente

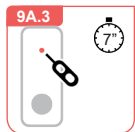

Pulsar SET durante 7 seg.

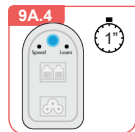

El indicador AZUL se iluminará pasado 1 seg.



BORRADO COMPLETO realizado

9B. Borrado completo desde el Motor

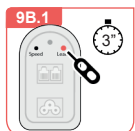

Pulsar SET durante 3 seg.

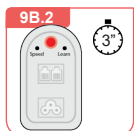

El indicador ROJO parpadeará lentamente pasados 3 seg.

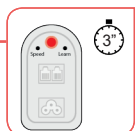

El indicador ROJO parpadeará rápidamente pasados 3 seg.

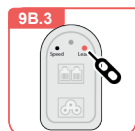

Pulsar SET de nuevo.

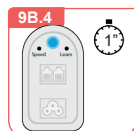

El indicador AZUL se iluminará pasado 1 seg.



BORRADO COMPLETO realizado

Advertencias



Riesgo eléctrico



Riesgo de atrapamiento



No golpear el dispositivo



No perforar el dispositivo



Mantener alejado de líquidos o sustancias corrosivas

Resolución de problemas

Problemas	Causas	Soluciones
El motor no funciona o funciona muy despacio.	A - Sobrecarga. B - Instalación incorrecta. C - Voltaje incorrecto	A - Comprobar peso cortina. B - Comprobar componentes. C - Comprobar alimentación.
El motor se detiene mientras está funcionando.	A - Fallo del suministro. B - El motor alcanzó un Final de Carrera. C - El motor funcionó continuamente durante 5 min.	A - Comprobar suministro. B - Pulsar sentido contrario. C - Repetir orden otra vez.
El motor no funciona al tirar de la cortina 5 cm.	A - Función Light Touch desactivada. B - Se ha sobrepasado un Final de Carrera.	A - Activar función Light Touch. B - Mover la cortina en sentido contrario hasta alcanzar el Final de Carrera

Installing the motor

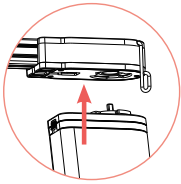

Insert Motor into the Pulley

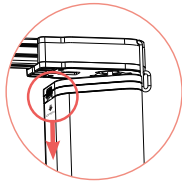

Slide down the lock button

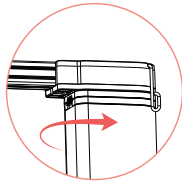

Turn the Motor and release the lock button

Remove the motor

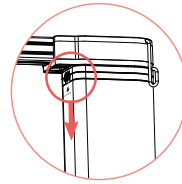

Slide down the lock button

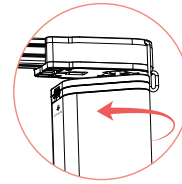

Turn the Motor while holding the lock button

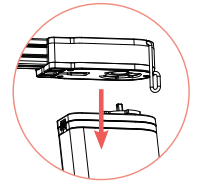

Remove the Motor

Wiring diagram

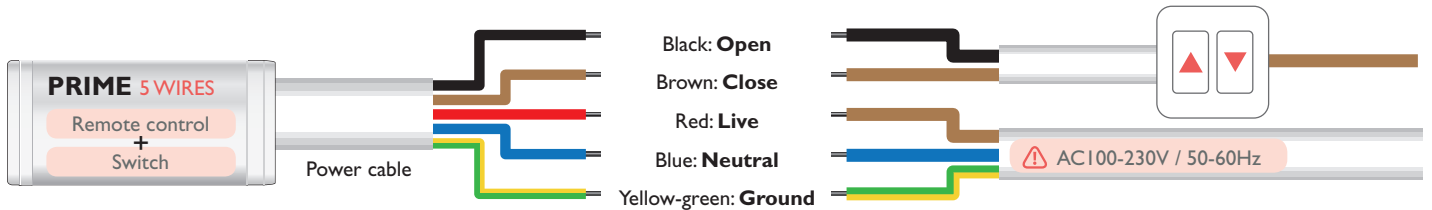
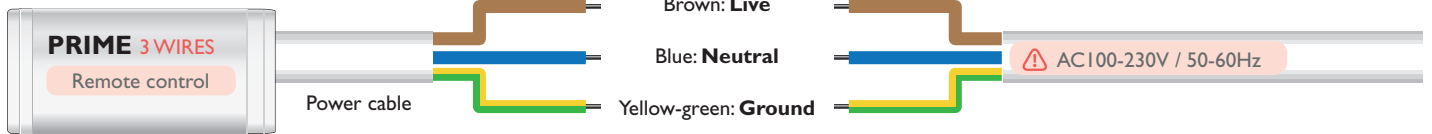

Remote control

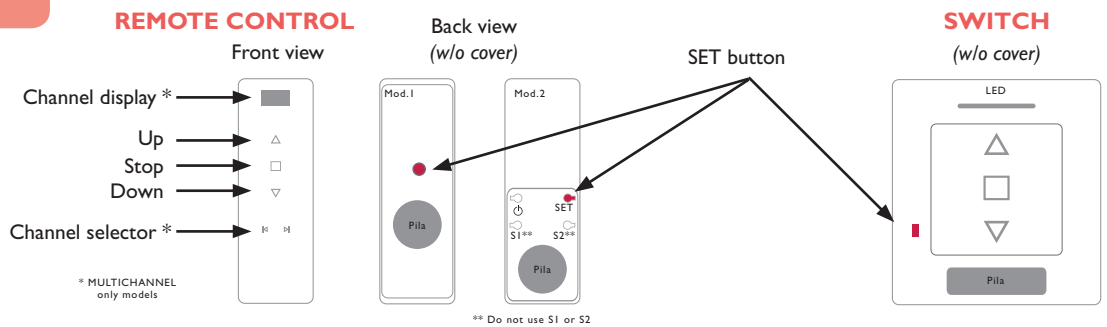

Motor

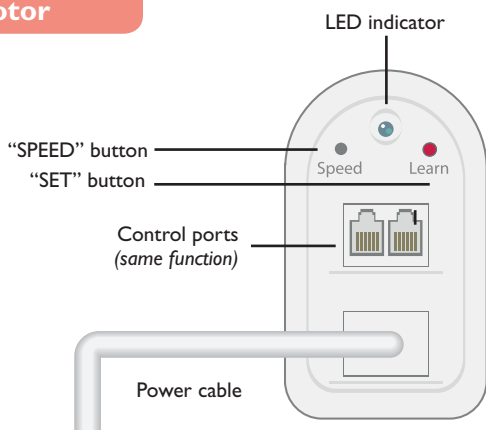

Control cable connection (optional)

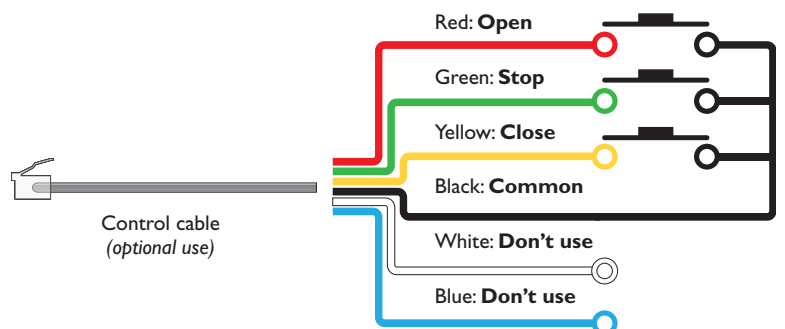

Basic settings

The time between operations must be lower than 10 seconds or the motor will leave the setting mode

1. Remote control / Channel setting

If a Multichannel Remote control is used, choose the channel first

 1.1 Press SET for 1 sec.	 1.2 RED indicator light will blink slowly	 1.3 Press UP once	 1.4 BLUE indicator light will blink 3 times	 1.5 REMOTE / CHANNEL added
--	---	-------------------------------------	---	--

2. Changing curtain opening direction (only if needed)

 2.1 Press STOP for 5 sec.	 2.2 RED indicator light will blink slowly	 2.3 Press STOP once	 2.4 BLUE indicator light will blink 3 times	 2.5 OPENING DIRECTION changed
---	---	---------------------------------------	---	---

Additional functions

The time between operations must be lower than 10 seconds or the motor will leave the setting mode

3. Enable / disable Light Touch function (Light Touch function: the motor will run automatically by pulling 5 cm of the fabric.)

This function is enabled by default

 3.1 Press SET for 7 sec.	 3.2 RED indicator light will blink slowly	 3.2 RED indicator light will blink quickly after 3 sec.	 3.3 BLUE indicator light will blink 3 times after 7 sec.	 3.4 LIGHT TOUCH function enabled/disabled
--	---	---	--	---

4. Changing motor speed level

The motor has 3 speed levels. The highest speed level is selected by default

 4.1 Press SPEED for 3 sec.	 4.2 BLUE indicator light will blink 3 times	 4.3 BLUE indicator: 101-130RPM PURPLE indicator: 81-100RPM RED indicator: 50-80RPM	 4.4 Press SET to change speed level	 4.5 Press SPEED for 3 sec.	 4.6 BLUE indicator light will blink 3 times	 4.6 SPEED LEVEL set
--	---	--	---	--	---	---------------------------------------

5. Setting Limit position

 5.1 Move until Limit to be adjusted	 5.2 Remove the cover to have access to button SET	 5.3 Press SET for 1 sec.	 5.4 BLUE indicator light will blink 3 times	 5.5 Adjust until desired position (also manually)	 5.6 Press SET for 1 sec.	 5.7 BLUE indicator light will blink 3 times	 5.8 LIMIT POSITION set
---	---	--	---	---	--	---	--

6. Adding new Remote Control / Channel using a programmed one

 6.1 Press STOP for 5 sec.	 6.2 RED indicator light will blink slowly	 6.3 Press UP in new Remote Control / Channel	 6.4 BLUE indicator light will blink 3 times	 6.5 NEW REMOTE CONTROL / CHANNEL added
---	---	--	---	--

7. Deleting Remote Control / Channel

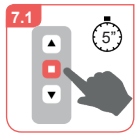

Press STOP for 5 sec.



RED indicator light will blink slowly

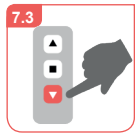

Press DOWN



BLUE indicator light will blink 3 times



REMOTE CONTROL / CHANNEL deleted

8. Lock / Unlock the quantity of available channels in multichannel remote controls

8A. Lock channels



Choose the number of maximum channels desired

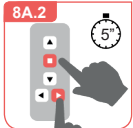

Press STOP and RIGHT arrow for 5 sec.



MAX. QUANTITY OF CHANNELS locked

8B. Unlock channels



Select any channel

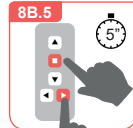

Press STOP and RIGHT arrow for 5 sec.



MAX. QUANTITY OF CHANNELS unlocked

Factory reset

⚠ The time between operations must be lower than 10 seconds or the motor will leave the setting mode

⚠ Factory reset deletes: Open and Closed Limits and Remote Controls / Channels

9A. Factory reset from the remote control

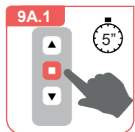

Press STOP for 5 sec.

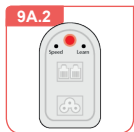

RED indicator light will blink slowly

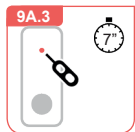

Press SET for 7 sec.

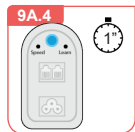

BLUE indicator will light 1 sec.



FACTORY RESET done

9B. Factory reset from the motor

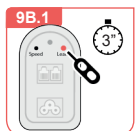

Press SET for 3 sec.

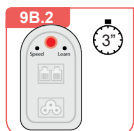

RED indicator light will blink slowly after 3 sec.

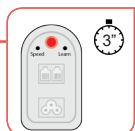

RED indicator light will blink quickly after 3 sec.

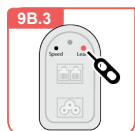

Press SET again

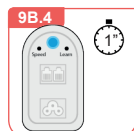

BLUE indicator will light 1 sec.



FACTORY RESET done

Warnings



Electric risk



Entrapment risk



Do not hit motor



Do not drill motor



Keep away from liquids and corrosive materials

Troubleshooting

Problems	Causes	Solutions
Motor does not work or do it slowly.	A - Incorrect voltage. B - Overloading. C - Incorrect installation.	A - Check voltage. B - Check curtain weight. C - Check components.
Motor stops suddenly.	A - Power failure B - Motor reached one of the Limits C - Motor worked continuously for 5 min.	A - Check supply B - Press opposite direction button C - Repeat order again
Motor does not work by pulling 5 cm of the fabric.	A - Light Touch function disabled B - A Limit has been exceeded	A - Enable Light Touch function B - Move the curtain in the opposite direction until reach the Limit

Installer le moteur

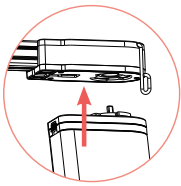

Insérez le moteur dans la poulie

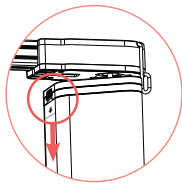

Faites glisser le bouton de verrouillage

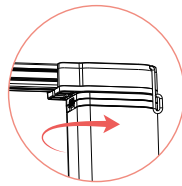

Tourner le moteur et relâcher le bouton de verrouillage

Retirer le moteur

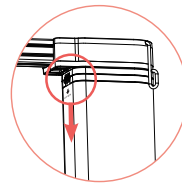

Faites glisser le bouton de verrouillage

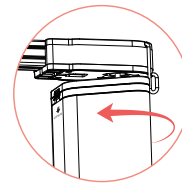

Tourner le moteur tout en maintenant le bouton de verrouillage

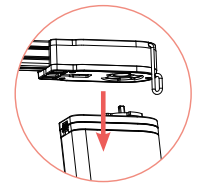

Retirer le moteur

Schéma de câblage

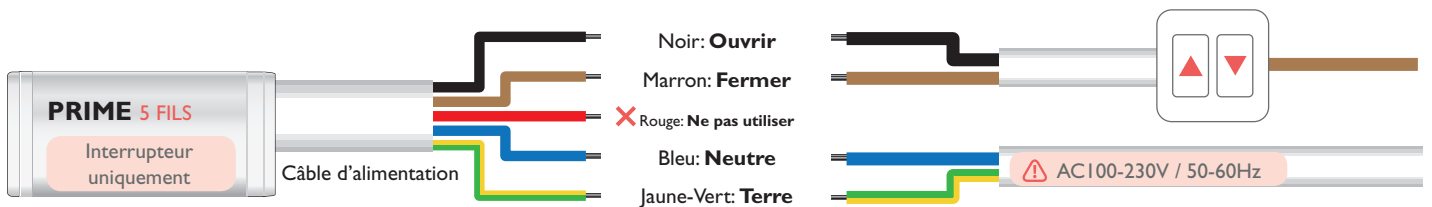
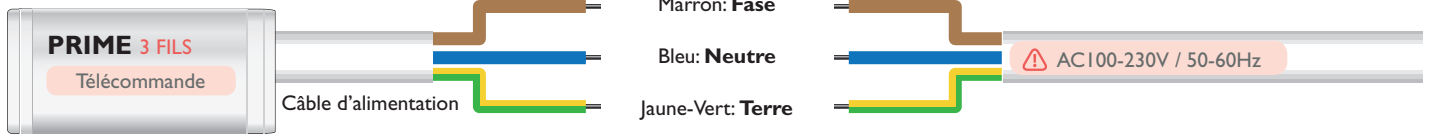

Boutons de programmation

Dans le TÉLÉCOMMANDE

Vue de face

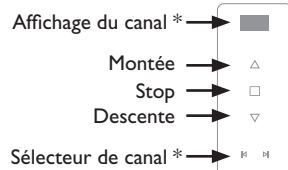

Vue arrière (sans couvercle)

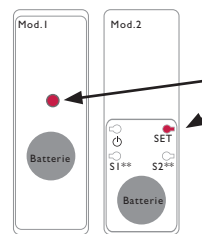

* Modèle MULTICANAL uniquement

** N'utilisez pas S1 ou S2

Dans le INTERRUPTEUR

(sans couvercle)

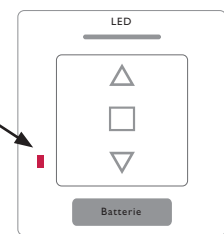

Moteur

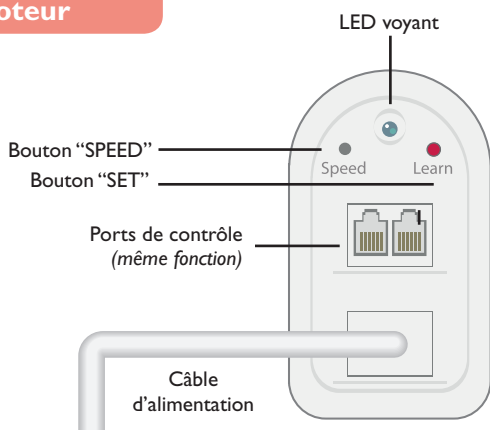

Connexion du câble de commande (facultatif)

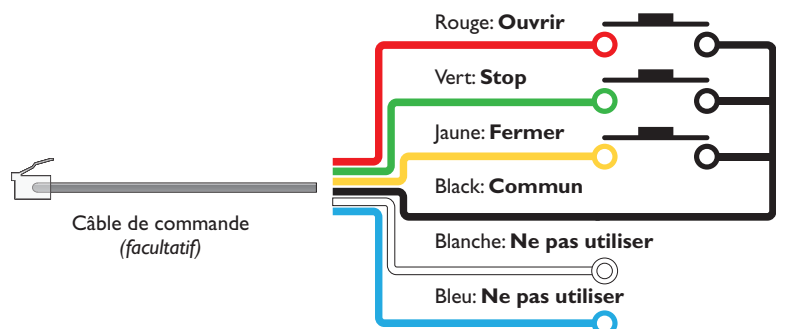

Programmation de base

⚠ Le temps entre les opérations doit être inférieur à 10 secondes ou le moteur quittera le mode de réglage

1. Réglage du télécommande / canal

⚠ Si une télécommande multicanal est utilisée, choisissez d'abord le canal.

				
Appuyez sur SET pendant 1 sec.	Le voyant ROUGE clignote lentement	Appuyez sur STOP une fois	Le voyant BLEU clignote 3 fois	TELECOMMANDE / CANAL programmé

2. Changer le sens d'ouverture du rideau (seulement si nécessaire)





				
Appuyez sur STOP pendant 5 sec.	Le voyant ROUGE clignote lentement	Appuyez sur STOP une fois	Le voyant BLEU clignote 3 fois	SENS D'OUVERTURE changée

Fonctions supplémentaires

⚠ Le temps entre les opérations doit être inférieur à 10 secondes ou le moteur quittera le mode de réglage



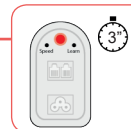

3. Activer / Désactiver Light Touch fonction (Light Touch fonction: le moteur fonctionnera automatiquement en tirant 5 cm de tissu.)

⚠ Cette fonction est activée par défaut

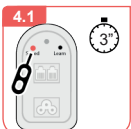
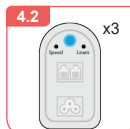
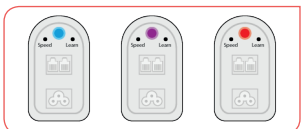

				
Appuyez sur SET pendant 7 sec.	Le voyant ROUGE clignote lentement	Le voyant ROUGE clignote rapidement après 3 sec.	Le voyant BLEU clignote 3 fois après 7 sec.	LIGHT TOUCH fonction activée / désactivée

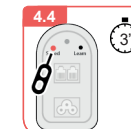
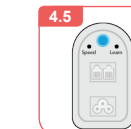
4. Modification du niveau de vitesse du moteur

⚠ Le moteur a 3 niveaux de vitesse. Le niveau de vitesse le plus élevé est sélectionné par défaut

						
Appuyez sur SPEED pendant 3 sec.	Le voyant BLEU clignote 3 fois	voyant BLEU: 101-130RPM voyant VIOLET: 81-100RPM voyant ROUGE: 50-80RPM	Appuyez sur SET pour changer de niveau de vitesse	Appuyez sur SPEED pendant 1 sec.	Le voyant BLEU clignote 3 fois	NIVEAU DE VITESSE programmée

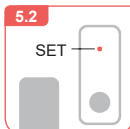
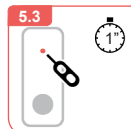
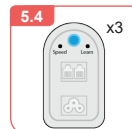
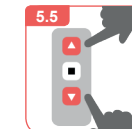
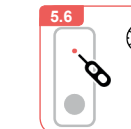
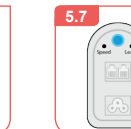
5. Réglage de la fin de course

							
Déplacer jusqu'à la FIN DE COURSE à ajuster	Enlever le couvercle pour accéder au bouton SET	Appuyez sur SET pendant 1 sec.	Le voyant BLEU clignote 3 fois	Déplacer jusqu'à la position désirée (aussi manuellement)	Appuyez sur SET pendant 1 sec.	Le voyant BLEU clignote 3 fois	NOUVELLE POSITION programmée

6. Ajout d'une nouvelle télécommande / canal à l'aide d'une télécommande programmée

				
Appuyez sur STOP pendant 5 sec.	Le voyant ROUGE clignote lentement	Appuyez sur MONTÉE une fois dans le nouvelle TELECOMMANDE / CANAL	Le voyant BLEU clignote 3 fois	NOUVELLE TELECOMMANDE / CANAL ajouté

7. Suppression de la télécommande / canal (télécommande à canaux multiples)

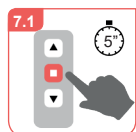

Appuyez sur STOP pendant 5 sec.



Le voyant ROUGE clignote lentement



Appuyez sur DESCENTE

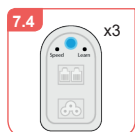

Le voyant BLEU clignotera 3 fois



TÉLÉCOMMANDE / CANAL supprimé

8. Verrouiller / Déverrouiller la quantité de canaux disponibles dans les télécommandes multicanaux

8A. Verrouiller canaux



Choisissez le nombre de canaux maximum souhaité

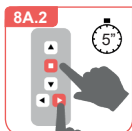

Appuyez sur STOP et la flèche DROITE pendant 5 secondes.



QUANTITÉ MAXIMALE DE CANAUX verrouillés

8B. Deverrouiller canaux



Sélectionnez n'importe quel canal

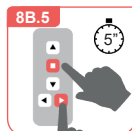

Appuyez sur STOP et la flèche DROITE pendant 5 secondes.



QUANTITÉ MAXIMALE DE CANAUX déverrouillés

Suppression de la mémoire complète (réinitialisation d'usine)

⚠ Le temps entre les opérations doit être inférieur à 10 secondes ou le moteur quittera le mode de réglage

⚠ La réinitialisation d'usine supprimera: Fins de course ouverts et fermés et télécommandes / canaux

9A. Réinitialisation d'usine depuis la télécommande

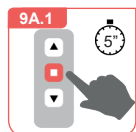

Appuyez sur STOP pendant 5 sec.

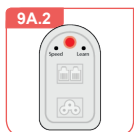

Le voyant ROUGE clignote lentement

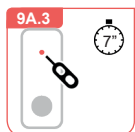

Appuyez sur SET pendant 7 sec

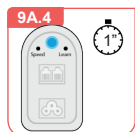

Le voyant BLEU clignotera 1 sec.



RÉINITIALISATION D'USINE effectuée

9B. Réinitialisation d'usine depuis le moteur

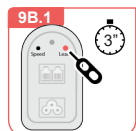

Appuyez sur SET pendant 3 sec.

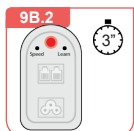

Le voyant ROUGE clignote lentement après 3 sec.

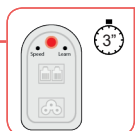

Le voyant ROUGE clignotera rapidement après 3 sec.



Appuyez à nouveau sur SET

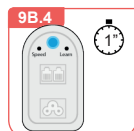

Le voyant BLEU clignotera 1 sec.



RÉINITIALISATION D'USINE effectuée

Avertissements



Risque électrique



Risque de coincement



Ne pas frapper le moteur



Ne pas percer le moteur



Tenir à l'écart des liquides et des matières corrosives

Troubleshooting Résolution de problème

Problème	Causes	Solutions
Le moteur ne fonctionne pas ou le fait lentement.	A - Tension incorrecte. B - Surcharge. C - Mauvaise installation.	A - Vérifier la tension. B - Vérifier le poids aveugle. C - Vérifier les composants.
Motor stops suddenly.	A - Panne de courant. B - Le moteur a atteint l'une des limites. C - Le moteur a fonctionné en continu pendant 5 min.	A - Vérifier l'alimentation. B - Appuyez sur le bouton de sens opposé. C - Répétez la commande à nouveau.
Motor does not work by pulling 5 cm of the fabric.	A - Fonction Light Touch désactivée B - Une limite a été dépassée	A - Activer la fonction Light Touch B - Déplacer le rideau dans le sens opposé jusqu'à atteindre le fin de course.